

LiquiScale Gen 2

Secure Level meter for pressurized cryogenic gas tanks



- Level meter for cryogenic gas storage
- High precision through SIL 2 differential pressure cell (drift over 10 years < 0,3%)
- Display of filling level, head pressure and range (configurable in kg, l, Nm³)
- Detection of critical tank situations
- LED colour display, bright with colour changes at exceedance of limit values, easily readable even at a 5m distance and in full sunlight
- Display of temperature corrected, true filling level possible
- Configurable analogue and relay outputs, adjustable filling marks
- Simple configuration via WLAN or USB
- Gaging independent of tank geometry
- Physical properties for many gases integrated usage of customer-specific geometry and density data possible.
- Suitable for oxygen
- Optional: Batterie buffer, LTE connection
- Remote version available

Technical data	
Measuring range	SIL 2 certified 500 mbar und 3000 mbar measuring cell standard, further ranges available on request
Nominal pressure / connection	Standard 160 bar, higher ranges on request / ¼ " NPT-18
Supply voltage	24VDC, optional 220VAC power supply w/o optional battery
Materials / Protection class	Cell: 1.4404 / 316L; housing: Polycarbonate; IP65
Display	Bright LED colour display for media, head pressure and filling level, (% , l, kg, Nm ³ at 0°C, 1013 mbar or 15°C, 1 bar); exceedance of limit → red flashing display, additional bargraph for filling level, automatic brightness control according to ambient light
Language versions, measuring units	D, F, GB standard; CZ, PL, HU, I, E, NL in preparation Switchable from Metric to Imperial (UK) / (US)
Output signals (galvanically isolated)	2 x analogue 0/4-20 mA output (load resistance max. 320Ω), 1 x selectable for filling level or differential pressure, 1 x head pressure; optional 2 x relays passive (24V, 1A, NO or NC) for fill and notify limits (trigger points individual adjustable)
Wireless signal transmission	LTE, platform independent or with J.con data service
Dimensions	width: 245 mm, height: 209 mm, depth: 197 mm
Weight / Protection class	4,2kg / IP65
Interfaces	WLAN (password protected), USB (with optional adapter)
Commissioning	Configuration of media, output signals, limit and alarm values, displayed units, language version und tank geometry via PC or tablet with free of charge Windows Software
Accessories (optional)	Universal adapter for div. pressure pipe distances, valve block, batterie buffer, USB / mains adapter for on / offsite configuration

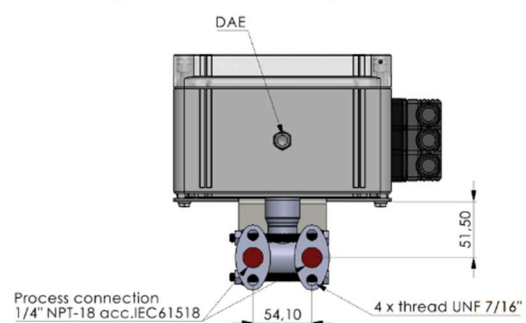
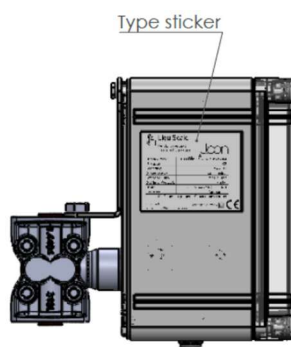
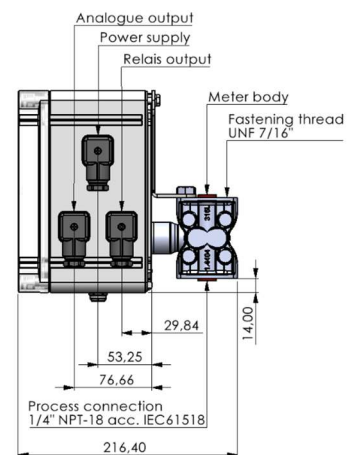
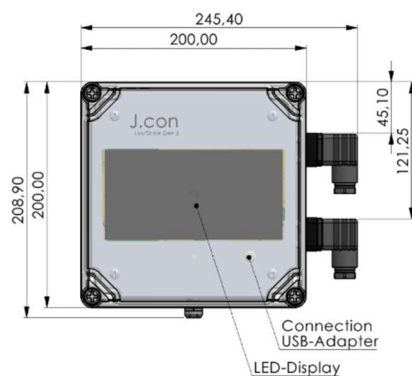

J.con GmbH, Erlenstrasse 13, 77815 Buehl Germany Fon +49 7223 28140-0
email: info@jcon-gmbh.com web: www.jcon-gmbh.com